

**JAMB ENLARGEMENT**

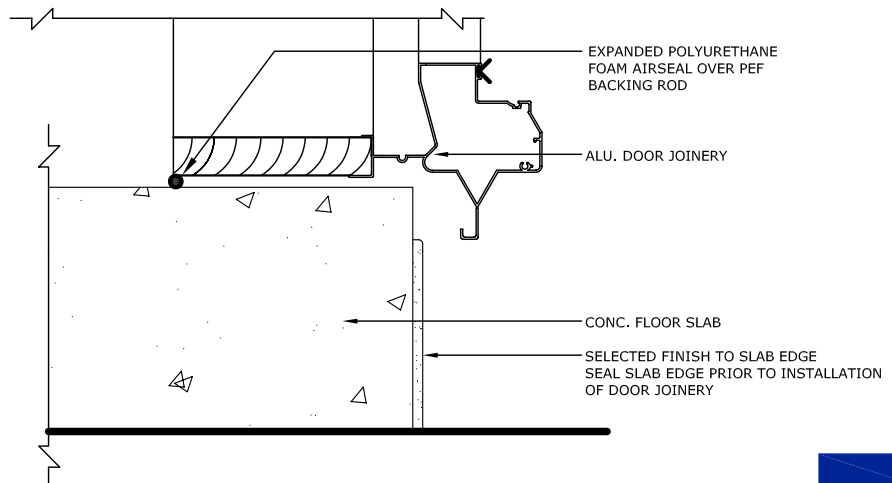
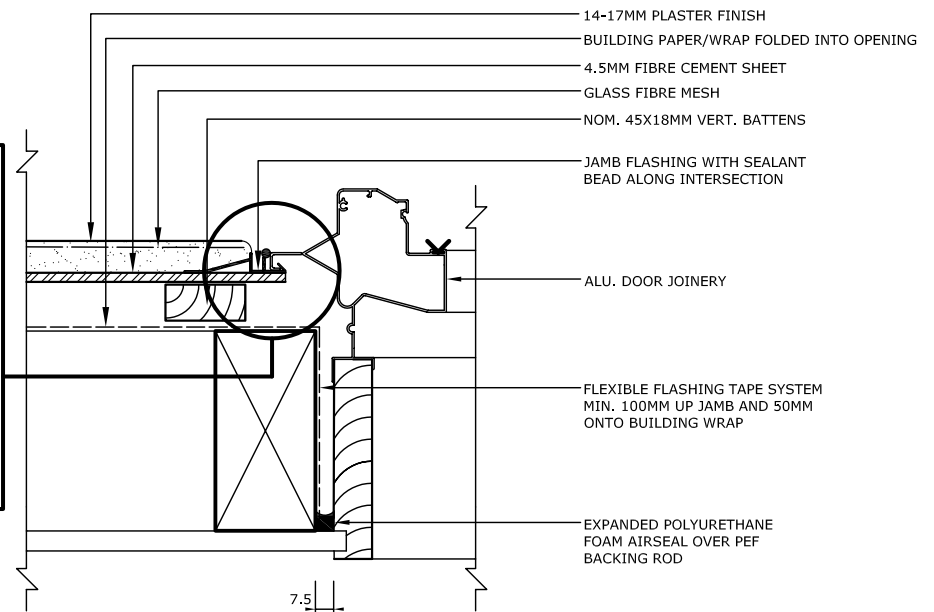

**NOTE:** FOR TIMBER FLOORS, A SLOPE WILL BE NEED TO BE FORMED IN THE FLOOR FINISH IF THE GLAZING POCKET OF THE DOOR FRAME IS LOCATED BACK PAST THE LINE OF THE FLOOR EDGE. REFER TO WINDOW MANUFACTURERS FOR METHOD OF FIXING SUPPORT.