



Nu-Therm Sponge Finish

March 2006

Paintworks Specification GS 425.6NZ

System	Grano Sponge Finish Satin
Substrate	Exterior – New and uncoated Grano Nu-Therm 40/60 cladding systems to extruded & expanded polystyrene sheets, mouldings and Polyblock.
Category	Premium Texture – Water Based

Product Features

Grano Sponge Finish® is a high performance pre blended modified cement based texturing material designed for use over Grano Adhesive Mortar® (G1.06NZ) or Grano Modified Render® (G1.10NZ). Grano Sponge Finish allows sponge, floated and various finishes to be achieved

Surface Preparation

Substrate must be free from dirt, dust, oil, grease, mould or any other contaminants that may affect adhesion.

Ensure the sheets are securely fixed in accordance with manufacturer's current specifications. Examine sheets to ensure that there is no possibility of future sheet movement.

The success of any sheet system is very much dependent on the correct construction of the framing, the fixing of the sheeting and the application of the rendering materials themselves. WattyL recommends that it is the responsibility of the Applicator to ensure that the substrate is of an acceptable standard prior to the application of any Granosite coating system.

Surface preparation is the responsibility of the Builder, Renovator or Main Contractor and the Applicator.

Render the sheets with the Grano Adhesive Mortar® and GranoMesh™ rendering system for polystyrene. To access the Grano Nu-Therm 40/60 (Rendering Guide and Detail Drawings) Installation Guide, contact WattyL (NZ) Ltd for the regional Granosite Sales Consultant's contact details.

Application Details	Data Sheet	Coverage	Film Thickness (microns)		Dry Times	
			Wet	Dry	Touch	Topcoat
First Coat: Grano Sponge Finish (equipment: trowel to the desired effect)	G1.25NZ	3.00Kg/M ²	2000	-	15 min	7 days
Second Coat: GranoPrime® (equipment: roller or spray)	G1.02NZ	0.08 L/M ²	80	20	2 hours	6 hours
Third & Fourth Coat: GranoImpact® (equipment: roller, for spray application refer the datasheet)	G2.01NZ	0.12 L/M ²	125	60	4 hours	6 hours

Recommended Uses

For exterior and interior use.

Grano Sponge Finish may be applied to off-form concrete Class 2 (AS 1510) or equivalent, cement rendered fair-faced flush-jointed concrete block and brickwork (common, clay, concrete), tilt-up and pre-cast concrete, proprietary fibre cement boards and Autoclaved Aerated Concrete (AAC). See the appropriate system specification sheet for further details.

Additional Notes

Surface preparation is the responsibility of the Builder, Renovator or Main Contractor and the Applicator. To achieve the indicated performance, it must be carried out according to WattyL's E.I.F.S Rendering Guide and E.I.F.S Detail Drawing recommendations.

It is recommended that application be carried out by a skilled applicator, who is totally conversant with the WattyL Granosite products and systems, to validate full material warranty conditions.

Caution

Provide adequate ventilation during use.

Application **should not** be carried out if the air temperature or the substrate temperature is below 10°C or above 35°C. The temperature must not fall below 10°C during the drying process.

1. This information is provided with respect to the listed WattyL products. WattyL recommends that:

(a) you review the Technical Data Sheets (TDS) and Material Safety Data Sheets (MSDS) before you use or handle the product; (b) the product be used only in accordance with the information provided by WattyL; (c) the product be transported, stored and handled in accordance with the information on the MSDS and relevant TDS; and (d) you thoroughly test the product, using the recommended application method on a sample of intended substrate, before using the product.

2. The information in this specification sheet was prepared using information gathered during product development. While WattyL endeavours to update this information and maintain the accuracy and currency of its contents, WattyL cannot guarantee that the information provided is wholly comprehensive.

3. WattyL recommends that you conduct such additional investigations as may be necessary to satisfy yourself of the accuracy, currency and comprehensiveness of the information on which you rely in using and handling the product. If you require further information please contact your nearest WattyL Office.

4. To the full extent permitted by law, WattyL's liability for breach of a condition or warranty implied into the contract for sale between WattyL and you by law is limited at WattyL's election to: (a) the replacement of the product; or (b) payment of the cost of replacing the product.

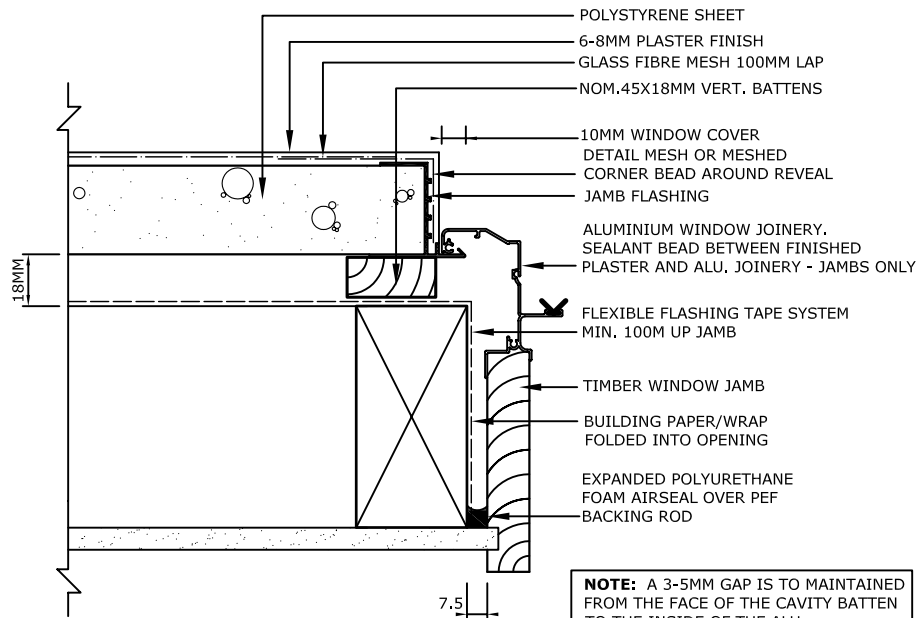
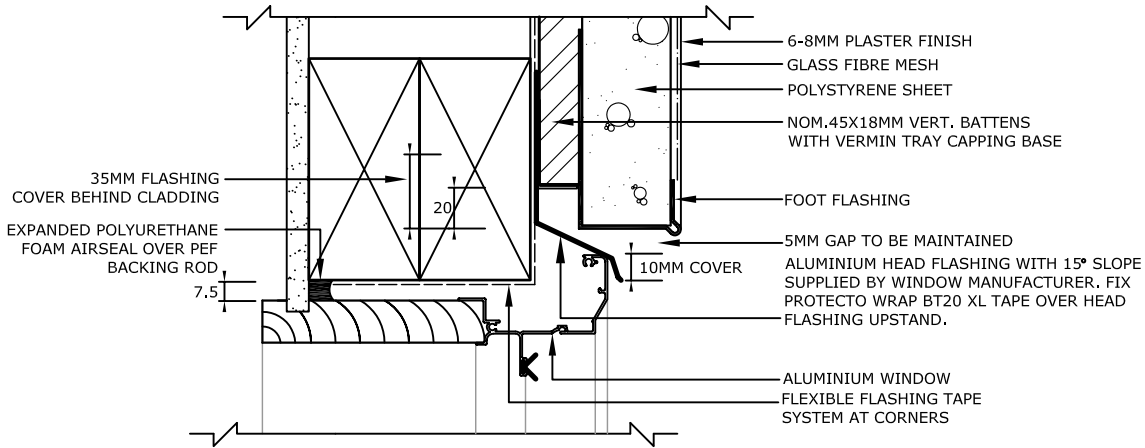

NOTE: A 3-5MM GAP IS TO MAINTAINED FROM THE FACE OF THE CAVITY BATTEN TO THE INSIDE OF THE ALU. JOINERY PROFILE TO FIT FLASHINGS

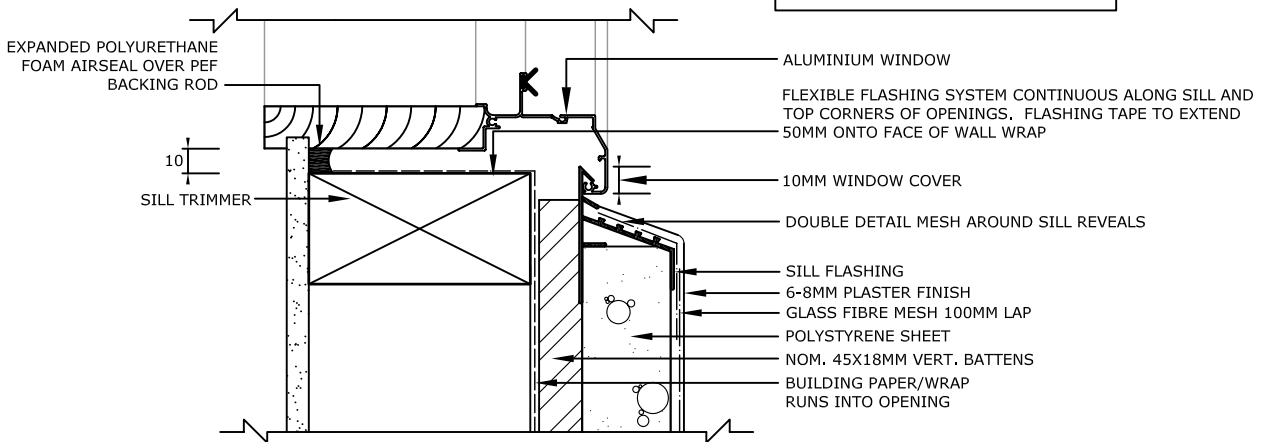

NOTE: A SLOPED SILL TRIMMER IS REQUIRED WHEN THE GLAZING POCKET OF THE WINDOW/DOOR FRAME IS POSITIONED BACK PAST THE LINE OF THE WALL FRAME. A FLAT SILL TRIMMER MAY BE USED IN ALL OTHER CIRCUMSTANCES. REFER TO WINDOW MANUFACTURERS FOR METHOD OF FIXING SUPPORT.

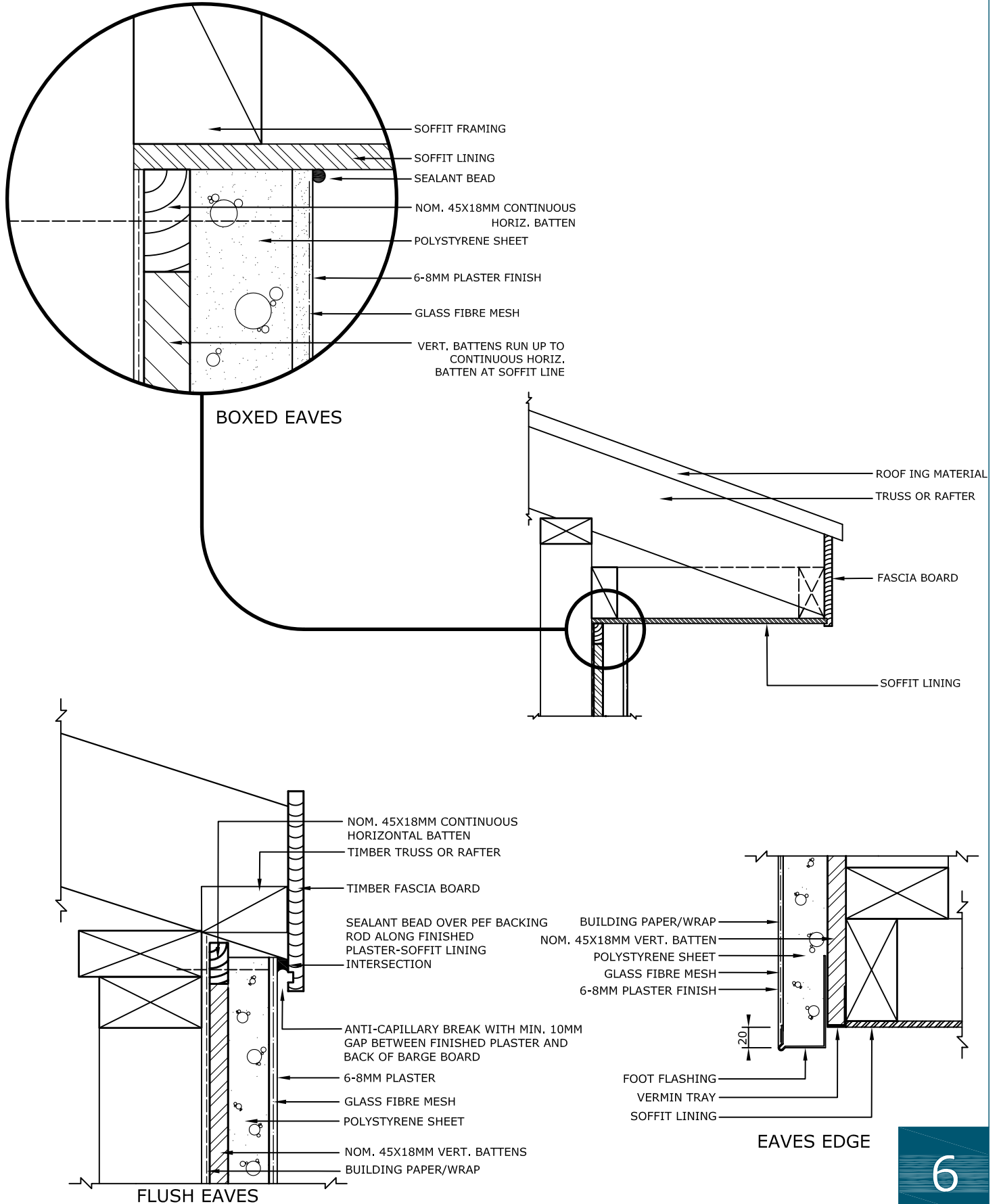

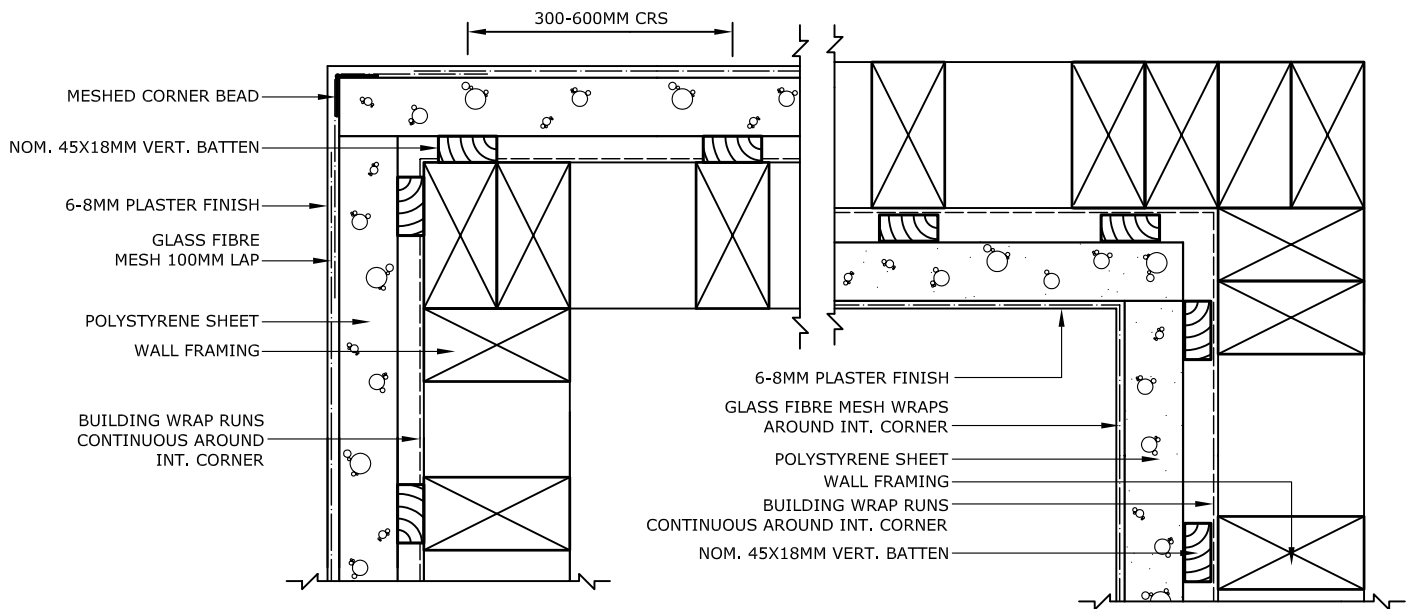

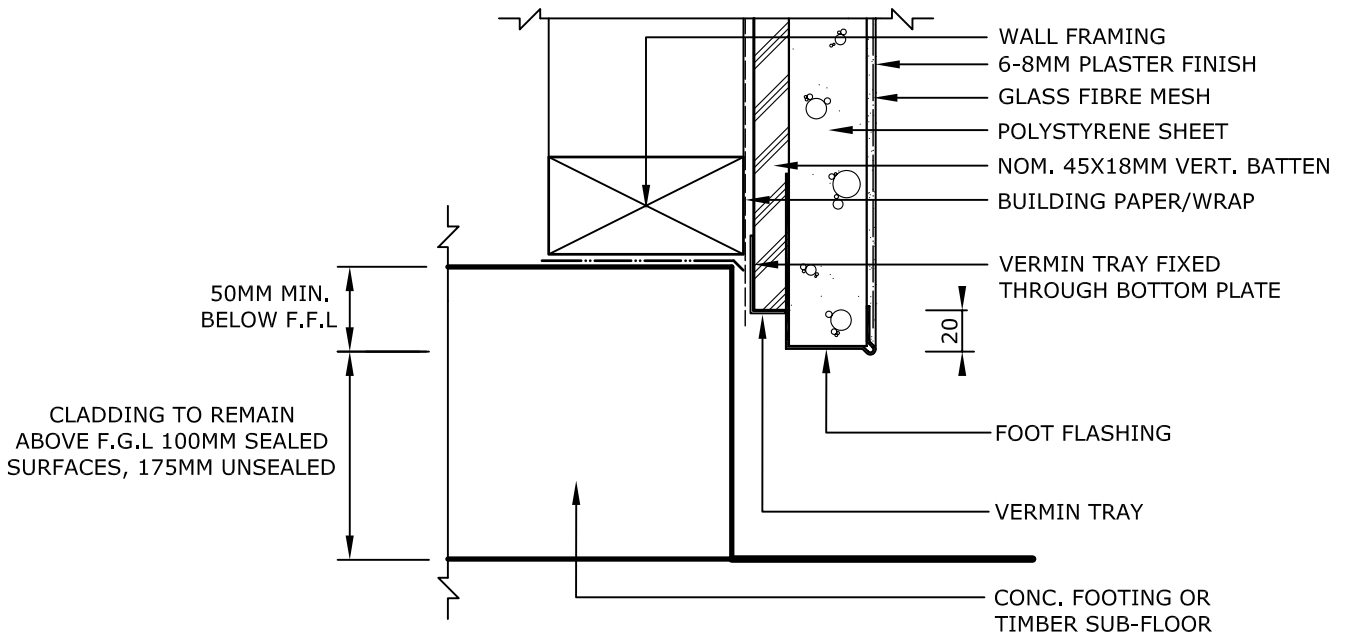

NOTE: OPENINGS IN THE VERMIN TRAY ARE SUFFICIENT TO ACHIEVE VENTILATION OPENINGS OF 1000mm² PER LINEAL METER

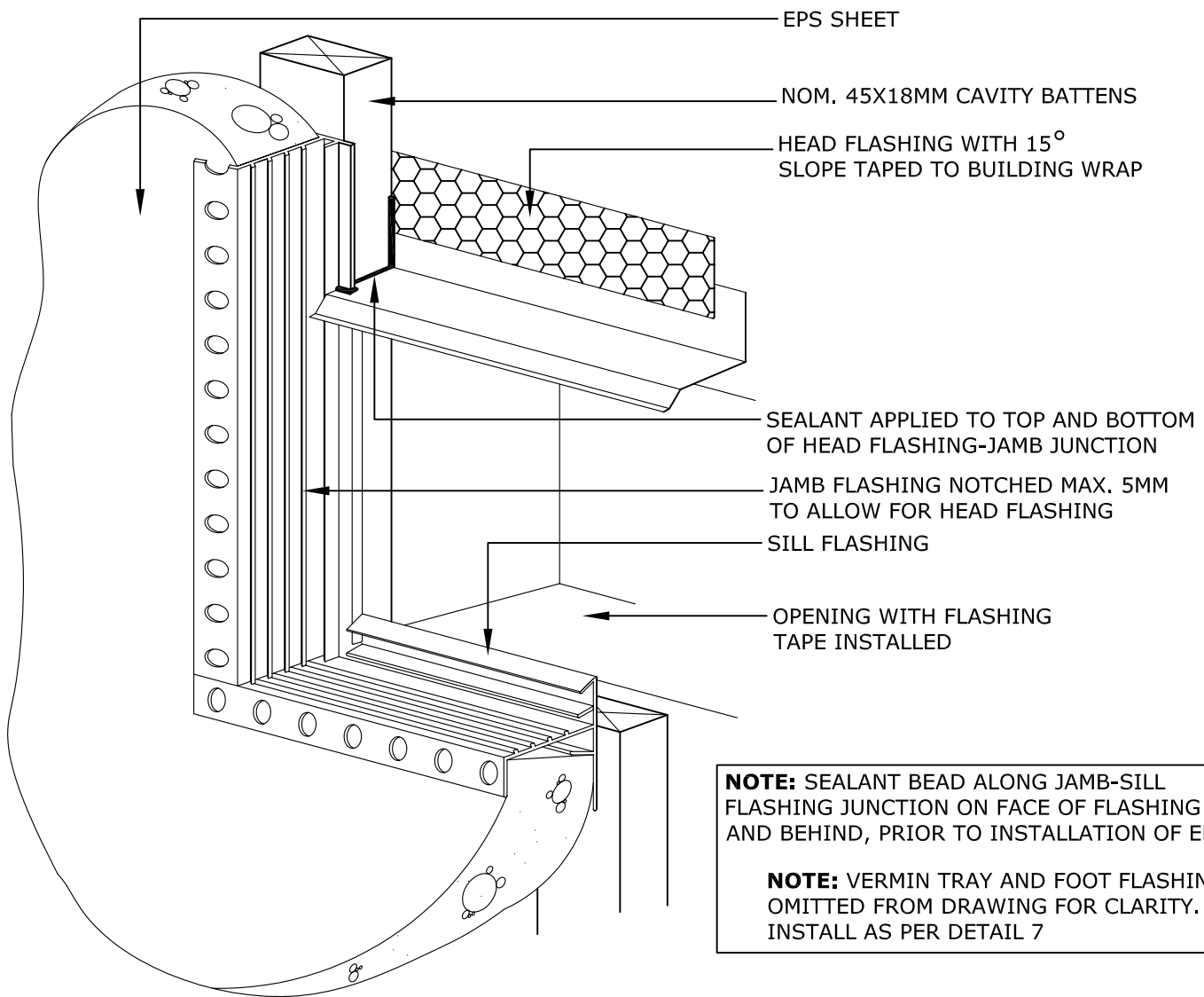

Grano Sponge Finish® formerly GranoSponge

Page 1 of 2
Resource Code
October 2005

DESCRIPTION

- Grano Sponge Finish® is a high performance pre blended modified cement based texturing material designed for use over Grano Adhesive Mortar® (G1.06NZ) or Grano Modified Render® (G1.10NZ).

PRINCIPAL CHARACTERISTICS

- Suitable for interior or exterior use.
- Formulated to produce sponge, floated and various other finishes.
- Can be applied between 2-3mm thicknesses in one application.
- Easy to apply and can being pumpable can offer economies in time and labour

COLOURS AND GLOSS

- Grey

BASIC DATA AT 25°C

- **Surface Dry** 15 minutes
- **Recoat** Twenty four (24) hours, if required
- **Fully Cured** Seven (7) days
All figures are quoted at 25°C and 50% Relative Humidity. Drying will take longer at lower temperatures or higher relative humidity.
- **Consistency** Dry powder
- **Texture** Grainy
- **Pot-Life** Two - Three (2-3) hours when mixed.
- **Coverage per coat** 3.00Kg/M² per 2mm film thickness
- **Clean-up** Thoroughly clean equipment with water.
- **Weatherability** Excellent
- **Abrasion Resistance** Excellent

RECOMMENDED SUBSTRATE CONDITIONS AND TEMPERATURE

- Grano Sponge Finish® is suitable for application to rendered surfaces such as Grano Adhesive Mortar® (G1.06NZ) or Grano Modified Render® (G1.10NZ).
- Surface Preparation is the responsibility of the Builder, Renovator or Main Contractor and the Applicator. To achieve the indicated performance, application must be carried out according to Watty's recommendations.
- Ensure the surface is clean and dry. All substrates must be free of dirt, grease, oil, mould, release agents, bondbreakers or any other contaminants that may interfere with adhesion. There must be less than 15% moisture Wood Equivalent in the surface at the time of coating to ensure optimum coating performance.
- Application **should not** be carried out if the air temperature or the substrate temperature is below 5°C or above 35°C.
- Freshly applied material must be protected from frosts and rain for a minimum of forty eight (48) hours.
- Not suitable for walk on surfaces.

INSTRUCTIONS FOR USE

- Mix one (1) 25 kg bag of Grano Sponge Finish® to approximately 4.0 litres of water. Add the powder to the water steadily and mix with a power stirrer until it is smooth and lump free. Grano Sponge Finish® has a pot-life of 15 minutes when mixed.
- Trowel one (1) coat of Grano Sponge Finish® using a stainless steel trowel at 3.00Kg/M² per 2mm film thickness. Allow 24 hours to dry.

Curing

- Keep damp for the first 12 hours to ensure full strength is developed. This is critical in windy conditions or when humidity is low.
- Allow to fully cure for 7 days or when moisture content is no greater than 15% wood equivalent before top coating.

SAFETY DATA

- **Caution** Provide adequate ventilation during use. Avoid inhalation of the powder, prolonged skin contact and particularly eye contact. Wear protective clothing to minimise skin contact and wear goggles where splatter is likely.
- **Spills and Disposal** Do not allow spill material to enter drains or other watercourses. Sweep up and dispose of waste in sealed containers to minimise dust. Disposal of waste is subject to statutory control. Consult your local authority for disposal guidelines.
- **M.S.D.S.** A Material Safety Data Sheet (M.S.D.S.) is available on request.
- **First Aid**
If swallowed **do not** induce vomiting. Give plenty of water to drink. Contact a doctor or the Poisons Information Centre. Phone 0800 764766 (New Zealand).
If in eyes, hold eyes open and flood with water for at least 15 minutes. Contact a doctor if any irritation occurs.
If on skin remove contaminated clothing, wash skin thoroughly with soap and water or a proprietary skin cleanser. Do not use solvents.
If affected by inhalation remove person to fresh air. If breathing difficulties persist or occur later, contact a doctor.

ADDITIONAL DATA

- Available in 25 kg bags.
- Bags must be kept dry during transportation and storage.
- **Shelf Life:** Six (6) months if stored appropriately. This must include storage under cover, above ground, away from direct heat and moisture and in well-sealed containers.
- It is recommended that application be carried out by a skilled applicator, who is totally conversant with the Granosite products and systems, to validate full material warranty conditions.
- For further information, contact the Watty! Information Helpline. Phone 0800 735551 (New Zealand).

GRANO SPONGE FINISH® IS A SURFACE PREPARATION PRODUCT AND IS USED IN CONJUNCTION WITH VARIOUS GRANOSITE SYSTEMS. AS SUCH IT IS NOT A SYSTEM IN ITSELF AND SHOULD ONLY BE USED WHERE SPECIFIED.

1. This information is provided with respect to the listed Watty! products. Watty! recommends that:

(a) you review the Technical Data Sheets (TDS) and Material Safety Data Sheets (MSDS) before you use or handle the product; (b) the product be used only in accordance with the information provided by Watty!; (c) the product be transported, stored and handled in accordance with the information on the MSDS and relevant TDS; and (d) you thoroughly test the product, using the recommended application method on a sample of intended substrate, before using the product.

2. The information in this technical data sheet was prepared using information gathered during product development. While Watty! endeavours to update this information and maintain the accuracy and currency of its contents, Watty! cannot guarantee that the information provided is wholly comprehensive.

3. Watty! recommends that you conduct such additional investigations as may be necessary to satisfy yourself of the accuracy, currency and comprehensiveness of the information on which you rely in using and handling the product. If you require further information please contact your nearest Watty! Office.

4. To the full extent permitted by law, Watty!'s liability for breach of a condition or warranty implied into the contract for sale between Watty! and you by law is limited at Watty!'s election to: (a) the replacement of the product; or (b) payment of the cost of replacing the product.

Grano Adhesive Mortar® formerly GranoPlast

Page 1 of 2
Resource Code 849504
July 2004

DESCRIPTION

- Grano Adhesive Mortar® Coarse or Fine is a high quality polymer modified, cementitious rendering material specifically designed for thin section rendering on expanded polystyrene sheets or blocks, bricks, AAC or over a base coat render.

PRINCIPAL CHARACTERISTICS

- Suitable for interior or exterior use.
- Applies with exceptional ease to provide a good adhesive surface for a finishing texture or plaster.
- Can be applied between 4-5mm thicknesses in one application.
- Superior application and adhesion properties when compared to conventional sand and cement render.
- Easy to apply and being pumpable can offer economies in time and labour.
- As a finish texture

COLOURS AND GLOSS

- Grey

BASIC DATA AT 25°C

- **Surface Dry** Fifteen (15) minutes
- **Recoat** Twenty four (24) hours, if required
- **Fully Cured** Seven (7) days
All figures are quoted at 25°C and 50% Relative Humidity. Drying will take longer at lower temperatures or higher relative humidity.
- **Consistency** Dry powder
- **Texture** Grainy
- **Pot-Life** Fifteen (15) minutes when mixed.
- **Coverage per coat** 4.00Kg/M² per 4mm film thickness
- **Clean-up** Thoroughly clean equipment with water.
- **Weatherability** Excellent
- **Abrasion Resistance** Excellent

RECOMMENDED SUBSTRATE CONDITIONS AND TEMPERATURE

- Grano Adhesive Mortar® is suitable for application to Expanded Extruded Polystyrene Sheets and Blocks, and Autoclaved Aerated Concrete (AAC) blocks or panels, off-form concrete and any other fair-faced, flush and straight laid concrete block or brickwork (common, clay).
- Surface Preparation is the responsibility of the Builder, Renovator or Main Contractor and the Applicator. To achieve the indicated performance, application must be carried out according to Watty's recommendations.
- Ensure the surface is clean and dry. All substrates must be free of dirt, grease, oil, mould, release agents, bondbreakers or any other contaminants that may interfere with adhesion. There must be less than 15% moisture Wood Equivalent in the surface at the time of coating to ensure optimum coating performance.
- **Note:** Porous substrates **must** be sealed with GranoSeal® (G1.14NZ) reduced 1:1 with water and applied by roller or spray at 0.12L/M² (8.3M²/L). Allow to dry 2-6 hours **prior** to applying Grano Adhesive Mortar®.
- Application **should not** be carried out if the air temperature or the substrate temperature is below 5°C or above 35°C.
- Freshly applied material must be protected from frosts and rain for a minimum of forty eight (48) hours.
- Not suitable for walk on surfaces.

INSTRUCTIONS FOR USE

- Mix one (1) 25 kg bag of Grano Adhesive Mortar® to approximately 4.0 litres of water. Add the powder to the water steadily and mix with a power stirrer until it is smooth and lump free. Grano Adhesive Mortar® has a pot-life of fifteen (15) minutes when mixed.
- Trowel one (1) coat of Grano Adhesive Mortar® using a stainless steel trowel at 4.00Kg/M² per 4mm film thickness. Allow 24 hours to dry.
- Apply an additional coat of Grano Adhesive Mortar® if required.

Curing

- Keep damp for the first 12 hours to ensure full strength is developed. This is critical in windy conditions or when humidity is low.
- Allow to fully cure for 24 hours or when moisture content is no greater than 15% wood equivalent before top coating.
- For Nu-Therm or Nu-Lite systems refer the Installation Guide.

SAFETY DATA

- **Caution** Provide adequate ventilation during use. Avoid inhalation of the powder, prolonged skin contact and particularly eye contact. Wear protective clothing to minimise skin contact and wear goggles where splatter is likely.
- **Spills and Disposal** Do not allow spilt material to enter drains or other watercourses. Sweep up and dispose of waste in sealed containers to minimise dust. Disposal of waste is subject to statutory control. Consult your local authority for disposal guidelines.
- **M.S.D.S.** A Material Safety Data Sheet (M.S.D.S.) is available on request.
- **First Aid**
If swallowed **do not** induce vomiting. Give plenty of water to drink. Contact a doctor or the Poisons Information Centre. Phone 0800 764766 (New Zealand).
If in eyes, hold eyes open and flood with water for at least 15 minutes. Contact a doctor if any irritation occurs.
If on skin remove contaminated clothing, wash skin thoroughly with soap and water or a proprietary skin cleanser. Do not use solvents.
If affected by inhalation remove person to fresh air. If breathing difficulties persist or occur later, contact a doctor.

ADDITIONAL DATA

- Available in 25 kg bags.
- Bags must be kept dry during transportation and storage.
- Shelf Life: Six (6) months if stored appropriately. This must include storage under cover, above ground, away from direct heat and moisture and in well-sealed containers.
- It is recommended that application be carried out by a skilled applicator, who is totally conversant with the Granosite products and systems, to validate full material warranty conditions.
- For further information, contact the WattyL Information Helpline. Phone 0800 735551 (New Zealand).

GRANO ADHESIVE MORTAR® IS A SURFACE PREPARATION PRODUCT AND IS USED IN CONJUNCTION WITH VARIOUS GRANOSITE SYSTEMS. AS SUCH IT IS NOT A SYSTEM IN ITSELF AND SHOULD ONLY BE USED WHERE SPECIFIED.

1. This information is provided with respect to the listed WattyL products. WattyL recommends that:
(a) you review the Technical Data Sheets (TDS) and Material Safety Data Sheets (MSDS) before you use or handle the product; (b) the product be used only in accordance with the information provided by WattyL; (c) the product be transported, stored and handled in accordance with the information on the MSDS and relevant TDS; and (d) you thoroughly test the product, using the recommended application method on a sample of intended substrate, before using the product.
2. The information in this technical data sheet was prepared using information gathered during product development. While WattyL endeavours to update this information and maintain the accuracy and currency of its contents, WattyL cannot guarantee that the information provided is wholly comprehensive.
3. WattyL recommends that you conduct such additional investigations as may be necessary to satisfy yourself of the accuracy, currency and comprehensiveness of the information on which you rely in using and handling the product. If you require further information please contact your nearest WattyL Office.
4. To the full extent permitted by law, WattyL's liability for breach of a condition or warranty implied into the contract for sale between WattyL and you by law is limited at WattyL's election to: (a) the replacement of the product; or (b) payment of the cost of replacing the product.

GranoPrime®

Page 1 of 2
Resource Code 849405
July 2004

DESCRIPTION

- GranoPrime® is an acrylic primer sealer. GranoPrime® can be applied by brush, roller or spray, prior to the application of most of the WattyL Granosite texture systems.

PRINCIPAL CHARACTERISTICS

- Suitable for interior or exterior use.
- Ensures optimum performance of the complete coating system by stabilising irregularities in substrate absorption and mechanical strength.
- Speeds the application, controls the drying and ensures strong adhesion of topcoats to the substrate.
- On concrete, cement render and mortar joints, the use of GranoPrime® minimises the threat of loss of adhesion or other problems that may arise due to presence of residual alkali salts.
- As an acrylic, GranoPrime® is not subject to the degradation that can occur with polyvinyl acetates (PVAs) in an alkaline environment.

COLOURS AND GLOSS

- Off-white

BASIC DATA AT 25°C

- **Surface Dry** Two (2) hours
- **Recoat** Two (2) to six (6) hours
All figures are quoted at 25°C and 50% Relative Humidity. Drying will take longer at lower temperatures or higher relative humidity.
- **Density** 1.04 kg/L
- **Consistency** Milky liquid
- **Coverage per coat** 0.08L/M² (12.5M²/L)
- **Wet Film Thickness** 80 microns (approx)
- **Dry Film Thickness** 20 microns (approx)
- **Thinning**

High Absorption Substrates	Mix 1 part GranoPrime® with 1 part water.
Medium Absorption Substrates	Mix 2 parts GranoPrime® with 1 part water.
Low Absorption Substrates	Use GranoPrime® undiluted.
- **Clean-up** Thoroughly clean equipment with water.

RECOMMENDED SUBSTRATE CONDITIONS AND TEMPERATURE

- **High Absorption Substrates:** Concrete block, cement render, brick, CFC and fibre cement sheeting, CSR™ Hebel® Autoclaved Aerated Concrete (AAC), coloured renders, lime washes, Grano Adhesive Mortar® (G1.06NZ), Grano Modified Render® (G1.10NZ), GranoReady Render® (G1.12NZ), GranoPatch Smooth (G1.04NZ), GranoFlex® (G1.15NZ).
- **Medium Absorption Substrates:** Off-form concrete under 40mpa, Polystyrene panels.
- **Low Absorption Substrates:** Previously painted surfaces, off-form concrete over 40mpa, high density bricks.
- GranoPrime® is **not suitable** for application to steel or timber substrates.
- Surface Preparation is the responsibility of the Builder, Renovator or Main Contractor and the Applicator. To achieve the indicated performance, application must be carried out according to WattyL's recommendations.
- Ensure the surface is clean and dry. All substrates must be free of dirt, grease, oil, mould, release agents, bondbreakers or any other contaminants that may interfere with adhesion. Fresh concrete substrates should be left for a minimum of 28 days before coating; fresh plaster surfaces should be left for a minimum of 14 days. There must be less than 15% moisture Wood Equivalent in the surface at the time of coating to ensure optimum coating performance.
- Application **should not** be carried out if the air temperature or the substrate temperature is below 10°C or above 35°C. The temperature must not fall below 10°C during the drying process.
- Freshly applied material must be protected from frosts and rain for a minimum of forty eight (48) hours.

INSTRUCTIONS FOR USE

- Stir contents thoroughly with a power stirrer before use.
- Apply one (1) coat to a correctly prepared surface by brush, roller or spray.
- Airless Spray Settings: Tip - 519-521 Pressure - 1500 – 2000 psi

SAFETY DATA

- **Caution** Provide adequate ventilation during use.
- **Spills and Disposal** Do not allow spill material to enter drains or other watercourses. Absorb spills with sand or other inert material. Unwanted paint should be kept in a sealed container, such as an empty paint can, and disposed of via special waste collection services. Check with your local Council regarding the disposal of empty paint containers
- **M.S.D.S.** A Material Safety Data Sheet (M.S.D.S.) is available on request.
- **First Aid**
If swallowed **do not** induce vomiting. Give plenty of water to drink. Contact a doctor or the Poisons Information Centre. Phone 0800 764766 (New Zealand).
If in eyes, hold eyes open and flood with water for at least 15 minutes. Contact a doctor if any irritation occurs.
If on skin remove contaminated clothing, wash skin thoroughly with soap and water or a proprietary skin cleanser. Do not use solvents.
If affected by inhalation remove person to fresh air. If breathing difficulties persist or occur later, contact a doctor.

ADDITIONAL DATA

- Available in 15 litre containers.
- Containers must be secured and stored upright during transit.
- Containers must not be exposed to excessive heat or cold.
- Storage must be under cover, away from direct heat, freezing and moisture, in well-sealed containers.
- It is recommended that application be carried out by a skilled applicator, who is totally conversant with the Granosite products and systems, to validate full material warranty conditions.
- For further information, contact the Watty Information Helpline. Phone 0800 735551 (New Zealand).

GRANOPRIME® IS A SURFACE PREPARATION PRODUCT AND IS USED IN CONJUNCTION WITH VARIOUS WATTYL GRANOSITE SYSTEMS. AS SUCH IT IS NOT A SYSTEM IN ITSELF AND SHOULD ONLY BE USED WHERE SPECIFIED.

1. This information is provided with respect to the listed Watty products. Watty recommends that:
(a) you review the Technical Data Sheets (TDS) and Material Safety Data Sheets (MSDS) before you use or handle the product; (b) the product be used only in accordance with the information provided by Watty; (c) the product be transported, stored and handled in accordance with the information on the MSDS and relevant TDS; and (d) you thoroughly test the product, using the recommended application method on a sample of intended substrate, before using the product.
2. The information in this technical data sheet was prepared using information gathered during product development. While Watty endeavours to update this information and maintain the accuracy and currency of its contents, Watty cannot guarantee that the information provided is wholly comprehensive.
3. Watty recommends that you conduct such additional investigations as may be necessary to satisfy yourself of the accuracy, currency and comprehensiveness of the information on which you rely in using and handling the product. If you require further information please contact your nearest Watty Office.
4. To the full extent permitted by law, Watty's liability for breach of a condition or warranty implied into the contract for sale between Watty and you by law is limited at Watty's election to: (a) the replacement of the product; or (b) payment of the cost of replacing the product.

GranolImpact®

Page 1 of 3
Resource Code 84943 - Line
July 2004

DESCRIPTION

- GranolImpact® is a pure acrylic, high performance elastomeric coating able to be applied in a variety of styles by roller or spray.
- Approved to APAS 0118/2 & APAS 0117/3.

PRINCIPAL CHARACTERISTICS

- Suitable for interior or exterior use.
- GranolImpact® systems have good adhesion to a wide variety of substrates and have excellent resistance to mould and fungi.
- As an acrylic membrane, the vapour permeability of GranolImpact® is carefully controlled to form a barrier to external moisture, while allowing vapour in the substrate to escape. It is, however, not suitable for situations where hydrostatic pressure exists.
- GranolImpact® also forms the final topcoat of many other Granosite systems, extending the performance and overall protection of the system applied.
- GranolImpact® is water-based for applicator safety and ease of use.

COLOURS AND GLOSS

- Bases may be tinted as required. Refer to the Wattyl colour range including the authentic heritage range. May also be tinted to other competitor colour ranges through the Wattyl tinting system.
- It is recommended that, for exterior application, the light-fastness of the chosen colour be confirmed before ordering.
- Satin
- Colours of Light Reflectance Values (LRV) of less than 40% on fibrecement substrates and less than 35% on polystyrene boards or to polystyrene block permanent formwork substrates may result in unacceptable thermal movement and should not be used.

BASIC DATA AT 25°C

- **Surface Dry** Four (4) hours
 - **Recoat** Six (6) hours
 - **Hard Dry** Seven (7) days
- All figures are quoted at 25°C and 50% Relative Humidity. Drying will take longer at lower temperatures or higher relative humidity.
- | | | | |
|--|---|--|--|
| • Density | 1.33 Kg/L | | |
| • Consistency | Thick, creamy paste. | | |
| • Texture | Rolana | Low Profile | Airless |
| | (10-12mm pile roller) | (Fine black texture roller) | (Airless spray gun) |
| • Coverage per coat | 0.18 L/M ² (5.5M ² /L) | 0.25 L/M ² (4.0M ² /L) | 0.33 L/M ² (3.0M ² /L) |
| • Wet Film Thickness (per coat) | 180 microns (approx) | 250 microns (approx) | 330 microns (approx) |
| • Dry Film Thickness (per coat) | 85 microns (approx) | 120 microns (approx) | 160 microns (approx) |
| • Moisture Control | Excellent, however the coating must not be subject to hydrostatic pressure. | | |
| • Water Ponding | 50.5 - Excellent. (mg of water passed after 50 hours at 25°C and 50% relative humidity) | | |
| • Water Swelling | 39.6. (ASTM D-471 % increase weight by weight) | | |
| • Water Permeability | Passed (AS 2904 Appendix G - 6 metre head of water) | | |
| • Vapour Permeability | 12.6 (gm/ m ² /24 hrs) DIN 52615 (at 500um dry film build) | | |
| • Vapour Transmission | 25.0 (gm/m ² /24hrs) ASTM-E-96 (at 360um dry film build) | | |
| • Carbon Dioxide Diffusion | Rb =459.6m (Engelfried Method) | | |
| • Chloride Ion Diffusion | 1.3 x 10 ⁻⁹ cm ² sec ⁻¹ (Taywood in-house method) | | |
| • Abrasion Resistance | 5,000 cycles - Film integrity excellent (AS 1580 459.1) | | |
| • Salt Spray | No effect (AS 2331.3.1) | | |
| • Elongation | 524% (ASTM D-412 at 25°C) | | |
| • Tensile Strength | 36.4 kg/cm ² (ASTM D-412 at 25°C) | | |
| • Crack Bridging | 3.65 (Crack width bridged per unit dry film thickness) | | |
| • Dirt Pick-Up | 1 - on a scale of 0 - 5 where "0" is no dirt retained (AS 1580 481.1.4 12 months) | | |

BASIC DATA AT 25°C - continued

- **Early Fire Hazard (AS 1530.3)**

Ignitability	(0-20)	11
Spread of Flame	(0-10)	0
Heat Evolved	(0-10)	2
Smoke Developed	(0-10)	3
- **Thinning** Not required, but may be thinned with up to 10% water for cutting in and spray applications. Thinning rates for airless spray will vary according to the brand of equipment used.
- **Clean up** Thoroughly clean equipment with water.

RECOMMENDED SUBSTRATE CONDITIONS AND TEMPERATURE

- GranolImpact® may be applied to off-form concrete Class 2 (AS 1510) or equivalent, cement rendered fair-faced flush-jointed concrete block and brickwork (common, clay, concrete), CFC, tilt-up and pre-cast concrete and paperfaced plasterboard. Make-good of the substrate is necessary if substrate imperfections are to be eliminated. Please refer to separate Datasheets for Grano Adhesive Mortar® (G1.06NZ) or Grano Modified Render® (G1.10NZ), GranoPatch® Smooth (G1.04NZ).
- Surface Preparation is the responsibility of the Builder, Renovator or Main Contractor and the Applicator. To achieve the indicated performance, application must be carried out according to Watty's recommendations.
- Ensure the surface is clean and dry. All substrates must be free of dirt, dust, grease, oil, mould release agents, bondbreakers and any other contaminants that may interfere with adhesion. Fresh concrete substrates should be left for a minimum of 28 days before coating; fresh plaster surfaces should be left for a minimum of 14 days. There must be less than 15% moisture Wood Equivalent in the surface at the time of coating to ensure optimum coating performance.
- Application **should not** be carried out if the air temperature or the substrate temperature is below 10°C or above 35°C. The temperature must not fall below 10°C during the drying process.
- Freshly applied material must be protected from frosts and rain for a minimum of forty eight (48) hours.
- Not suitable for roofs, ponds etc or walk on surfaces.
- For specific substrate preparation, see relevant specification sheets.

INSTRUCTIONS FOR USE

- Stir contents thoroughly with a power stirrer before use.
- GranolImpact® is normally applied in a **two (2) coat** application by roller to achieve the desired texture finish or the specified dry film thickness to a correctly prepared and primed surface. GranolImpact® may be applied as a single finish coat on texture finishes over correctly prepared and primed surfaces by airless spray; however care must be taken to ensure an even overall finish is obtained.
- **AIRLESS GUN SETTINGS**

Tip	519 or 521	Pressure Setting	2500 to 3000 psi
-----	------------	------------------	------------------

SAFETY DATA

- **Caution** Provide adequate ventilation during use.
- **Spills and Disposal** Do not allow spill material to enter drains or other watercourses. Absorb spills with sand or other inert material. Unwanted paint should be kept in a sealed container, such as an empty paint can, and disposed of via special waste collection services. Check with your local Council regarding the disposal of empty paint containers
- **M.S.D.S.** A Material Safety Data Sheet (M.S.D.S.) is available on request.
- **First Aid**

If swallowed **do not** induce vomiting. Give plenty of water to drink. Contact a doctor or the Poisons Information Centre. Phone 0800 764766 (New Zealand).

If in eyes, hold eyes open and flood with water for at least 15 minutes. Contact a doctor if any irritation occurs.

If on skin remove contaminated clothing, wash skin thoroughly with soap and water or a proprietary skin cleanser. Do not use solvents.

If affected by inhalation remove person to fresh air. If breathing difficulties persist or occur later, contact a doctor.

ADDITIONAL DATA

- Available in 15 litre containers.
- Containers must be secured and stored upright during transit.
- Containers must not be exposed to excessive heat or cold.
- Storage must be under cover, away from direct heat, freezing and moisture, in well-sealed containers.
- It is recommended that application be carried out by a skilled applicator, who is totally conversant with the Granosite products and systems, to validate full material warranty conditions.
- For further information, contact the Wattyl Information Helpline. Phone 0800 735551 (New Zealand).

1. This information is provided with respect to the listed Wattyl products. Wattyl recommends that:
(a) you review the Technical Data Sheets (TDS) and Material Safety Data Sheets (MSDS) before you use or handle the product; (b) the product be used only in accordance with the information provided by Wattyl; (c) the product be transported, stored and handled in accordance with the information on the MSDS and relevant TDS; and (d) you thoroughly test the product, using the recommended application method on a sample of intended substrate, before using the product.

2. The information in this technical data sheet was prepared using information gathered during product development. While Wattyl endeavours to update this information and maintain the accuracy and currency of its contents, Wattyl cannot guarantee that the information provided is wholly comprehensive.

3. Wattyl recommends that you conduct such additional investigations as may be necessary to satisfy yourself of the accuracy, currency and comprehensiveness of the information on which you rely in using and handling the product. If you require further information please contact your nearest Wattyl Office.

4. To the full extent permitted by law, Wattyl's liability for breach of a condition or warranty implied into the contract for sale between Wattyl and you by law is limited at Wattyl's election to: (a) the replacement of the product; or (b) payment of the cost of replacing the product.

WARRANTY CONDITIONS

Wattyl Granosite® & Nu-Age products are thoroughly tested and manufactured under strict quality control with only first grade materials used. No responsibility however can be accepted for variations in the strength, colour, appearance, or workability brought about by on-site mixing procedures and curing conditions not within the control of Wattyl (NZ) Ltd or Nu-Age Plaster Ltd.

Issue of Manufacturer's Warranty (material only) by Wattyl (NZ) Ltd requires the submission of an Applicator's Warranty specifying:

- a) The Wattyl Granosite® coating system employed
- b) Wattyl Granosite® Products Used
- c) Project name and address
- d) Proof-of-sale invoices for materials used on the project
- e) The Builder/ Main contractor in conjunction with the Applicator signs and submits the approved Site Reference Area Acceptance form

And conditional upon:

- f) The system & products used are applied by a skilled Applicator in accordance with the Manufacturer's specifications and recommended methods of application.
- g) The substrate of the whole of the premises is substantially the same as the Site Reference Area.
- h) The product's components are stored in an approved manner and used within the recommended shelf life.

Note: Invoices for Wattyl Granosite® & Nu-Age materials, whether bought through Wattyl or outlets, must clearly state the date of purchase, products involved and all relevant batch numbers.

Wattyl (NZ) Ltd

Policy for All Written Coating Warranties

A written Job Specific Warranty will only be issued against a written Job Specification, issued prior to commencement of the paintwork, where representatives from Wattyl have had an opportunity to provide site assistance during the course of application or where reliable evidence is presented that confirms that recommended systems and procedures have been followed.

For high build structural coatings, such as those supplied under Granosite Systems, written Job Specific warranties are often required prior to final building signoff by the Territorial Authority. Because of the potential liability arising from the failure of a structural coating it is imperative that authorized Wattyl representatives have verified that the coating has been applied in accordance with published specifications. Therefore the policy still applies that a written Job Specific Warranty will only be issued against a written Job Specification, issued prior to commencement of the work, where authorized representatives from Wattyl have had an opportunity to provide site assistance during the course of application to ensure that recommended systems and procedures have been followed.

The Warranties offered under the Granosite System are;

Granosite Coating Systems - five year renewable, offered where Granosite finishes are used in conjunction with systems supplied by others.

Granosite Coating Systems – seven year renewable, recoat with Granosite finish at year 7.

Granosite Coating Systems – ten years where GranoSkin or GranoImpact have been applied over a solid substrate such as Concrete Block, AAC Block, Off-Form Concrete, Tilt Slab or Brick.

Granosite Nu-Age Cladding Systems – fifteen year renewable by recoating with a specific Granosite Finish between year 7 and 8.

Written Job Specific warranties are subject to the applicator certifying that the substrate was suitable for the application of the specified system/s and that the applicator will re-apply the specified coating system if repairs are necessary under the warranty.

The Granosite warranties are subject to an annual chemical/cleaner wash and an inspection for weather-tightness, with repairs as necessary. The annual inspection for weather-tightness should be carried out by a person with sufficient experience to identify any maintenance required.

Warranty Conditions

Warranties do not cover paint film breakdown partially or wholly due to the following causes

1. Damage caused by movement of the substrate or structural cracking.
2. Damage caused by hydrostatic pressure or entrapped moisture.
3. Damage caused by maltreatment, such as mechanical damage, either during installation or at some subsequent time.
4. Damage caused by faulty design and/or construction of the premises leading to weather-tightness issues.
5. Failure due to faulty application.
6. Natural weathering, loss of gloss, colour change or fair wear and tear.
7. Heat absorption of a colour selected with an LRV of less than 40%.
8. Failure to carry out the annual inspection as described.
9. Acts of God.

The liability of Wattyl (NZ) Ltd under any Warranty claim is limited to re-supply of the coating materials only.

APPLICATOR QUALITY ASSURANCE CHECKLIST

QMSF-S071 DATE: _____
 Specification # _____
 Applicator Co. _____ Contact _____ Ph/Fax: _____
 Owner _____
 Builder _____
 Architect _____
 Site Address _____ Situation: Industrial
 Project Start Date _____ Project Finish Date _____ Urban
 Building Consent Number _____ Colour Name _____ LRV% _____ Coastal
 Are there any endorsements on the Building Consent in relation to the Cladding Yes No Rural
 Action taken _____

BUILDERS SECTION

Wall Framing within tolerances: Yes No Windows installed correctly: Yes No
 Has Window Manufacturer been informed of cavity size and custom head flashing: Yes No All Window Flashings installed correctly: Yes No
 Building Wrap installed correctly: Yes No Level of Treatment _____ Date Roof on _____
 Framing Type: _____ Moisture Content _____ % Cladding erected/installed as per manufacturers specification
 Flashing Tape Installed Mid Floor Control Joints installed if required
 Penetrations Flashed

PRE INSTALLATION

Type of Battens Used: Timber Solid Polystyrene
 Have battens been installed to specifications: Yes No
 Have walls been checked for straightness and plumb? Yes No If no state why _____
 Tolerances over 3m _____
 Is the base of the cladding set at minimum 50mm below floor level: Yes No (Please state) _____
 Substrate: Off-Form Concrete Cement Render Brick & Concrete Blocks Tilt-up & Pre-cast Panels
 Autoclave Aerated Concrete (AAC) CFC Sheet Fibre Cement Sheet
 Extruded & Expanded Polystyrene Sheet Hardibacker Other specify _____

COUNCIL / BUILDING INSPECTOR SIGN OFF OF THE ABOVE CHECKLIST

.....

GRANOSITE / NU-AGE NU-THERM 40/60 (Expanded Polystyrene Cladding System)

Specification #

Area M2

Polystyrene Grano Foam <input type="checkbox"/>	Size 60mm <input type="checkbox"/> 40mm <input type="checkbox"/>	Other
Other <input type="checkbox"/>		
Specify		
Date Sheets Fixed	Nail Size 90mm <input type="checkbox"/> 110mm <input type="checkbox"/>	Other
Nu-Therm Washers used	1 st Coat	Batch #
Yes <input type="checkbox"/> No <input type="checkbox"/>		
Sheets nailed correctly for wind zone	2 nd Coat	Batch #
Yes <input type="checkbox"/> No <input type="checkbox"/>		
Nu-Therm Flashings used	3 rd Coat	Batch #
Yes <input type="checkbox"/> No <input type="checkbox"/>		
Flashings installed correctly	4 th Coat	Batch #
Yes <input type="checkbox"/> No <input type="checkbox"/>		
Flashings sealed and primed	5 th Coat	Batch #
Yes <input type="checkbox"/> No <input type="checkbox"/>		
Mesh used 4mm <input type="checkbox"/> 6mm <input type="checkbox"/>	6 th Coat	Batch #

Applicators Signature _____ Date _____ Builders Signature _____ Date _____

MAINTENANCE SCHEDULE

System Type	Age	Procedure
All Granosite Nu-Age Cladding and Coating Systems	Annually	<p>Chemical / detergent wash. Have the entire coated area inspected by a person with sufficient experience to identify any maintenance requirements to ensure weathertightness. Undertake all necessary repairs immediately.</p> <p><i>For hard to remove stains, refer to the stain removal guide.</i></p>
Granosite Coating Systems	7 Years	<p>After seven years exposure the following maintenance procedure is required to validate the <i>Granosite Seven-Year Renewable Warranty</i>. Chemical / Detergent wash to remove all surface contaminates. Complete all necessary repairs. Ensure surface is clean, dry and free from surface contaminates and suitable for painting prior to the application of each coat.</p> <p>Apply one or two coats of the current finish coat as specified by Watty (NZ) Ltd.</p> <p>Application for the Warranty must be within 30 days of completion of the work and is subject to an inspection by a Watty Granosite representative, plus presentation by the <i>applicator</i> of the completed Quality Assurance checklist and materials documentation. After receipt of the applicators' warranty request upon completion of this treatment, a new <u>Manufacturer's Warranty</u> may be issued for a period of seven years.</p>
Granosite Nu-Age Cladding Systems	Annually	<p style="text-align: center;"><u>Nu-Therm 40/60 or Nu- Lite Owner's Maintenance Schedule</u></p> <p>Inspections of the complete cladding surface must be carried out at least annually at the end of summer. Because of settling after disturbances to the ground during construction, and the slow moisture-loss shrinkage of concrete slabs, it is recommended that six-monthly inspections be made for the first three years.</p> <p>A person with sufficient experience to identify any maintenance required should carry out the annual inspection for weathertightness.</p> <p>Any cracks or damaged areas, including flashings and seals that have deteriorated, must be repaired immediately to ensure the integrity of the building envelope is maintained.</p> <p>Any damage to the substrate must be repaired in accordance with the substrate manufacturer's instructions followed by re-plastering and recoating to the same standard as the original GranoTherm System installation.</p> <p>If chemical free framing timber has been used, it is imperative that the maintenance of the cladding system is followed rigorously to ensure the minimum moisture ingress takes place to prevent expensive and extensive structural repair work.</p>

NOTE: The information in this sheet concerning the use and application of these products is believed to be correct at the date of printing, and is given in good faith. Watty (NZ) Limited reserves the right to alter the product and or specification without notice. The user should check the date of issue, and if more than 24 months have elapsed, should contact our nearest sales office to confirm that the information is still current. Because we cannot control the way these products may be used, or the conditions they may be exposed to, we can give no unconditional guarantees in respect of these products or their performance. However, certain guarantees may be implied by law.
 NZ Issue Date: September 2002